



## 28V DC APU (Auxiliary Power Unit)

# AREL AGP100

## TEKNİK ÖZELLİKLER

### MOTOR

- Kohler 15 LD 350
- 1 silindir
- 4 zamanlı
- Hava soğutmalı
- Dizel
- 3,000 d/dak
- 6.3Hp net çıkış gücü
- 230 gr/hp – saat yakıt tüketimi
- 349 cm<sup>3</sup> silindir hacmi

### ALTERNATÖR

- Arel üretimi
- 8 kutup
- 3.000 d/dak
- 200Hz
- Fırçasız
- 3 faz
- Senkron
- IP23
- H sınıfı izolasyon

### GENEL

- 28V DC
- 100A
- Monoblok akuple
- Koruyucu kafes şase içinde

### STANDARTLAR

- ISO 9001:2015
- CE
- MS 704F

### OPSİYONLAR

- 12V DC marşlı
- Farklı motor seçeneği

### BOYUTLAR

En	48 cm
Boy	71 cm
Yükseklik	54 cm
Ağırlık	65 kg

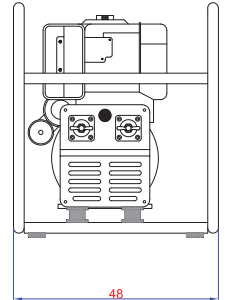
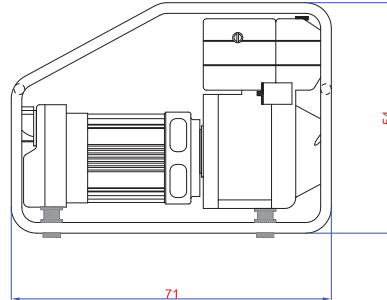

TS EN ISO 9001:2015

[www.arelgroundpower.com](http://www.arelgroundpower.com)  
[www.arelgpu.com](http://www.arelgpu.com)



### MERKEZ

1202/1 Cad. No:109-111  
06370 Ostim - Ankara, Türkiye  
Tel : +90 312 385 02 02 (Pbx)  
Faks : +90 312 385 08 14

### FABRİKA

Kırım Hanlığı Cad. No: 7, 1. OSB  
06935 Sincan - Ankara, Türkiye  
Tel : +90 312 267 58 38 (Pbx)  
Faks : +90 312 267 58 43